

REVELATION TRUMPETS

A medium bore moderately priced trumpet of exceptional performance. The outstanding feature of this model is the slight "edge" to its tone quality which makes it the preferred instrument with many trumpet players, especially for radio and recording work.

Responds very easily and quickly and with fine flexibility. Superior tuning even to an excellent middle D.

Top action valves. Bore .459, weight 39 ounces.

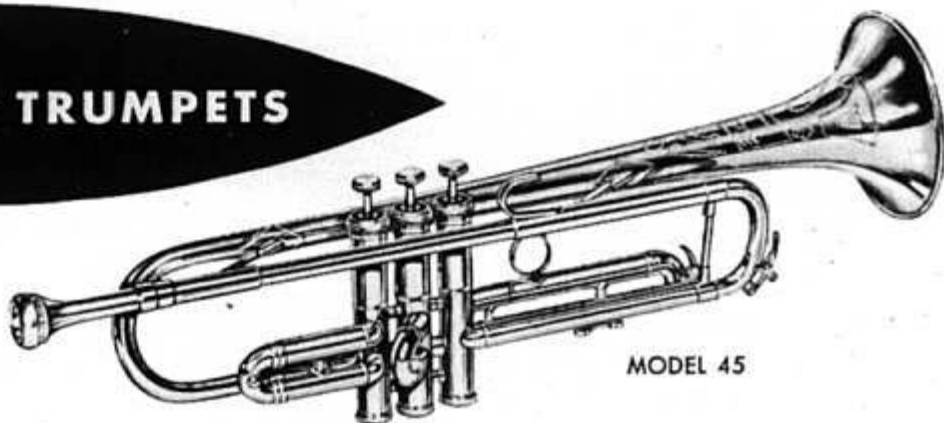

MODEL 45

MODEL 48 and 51

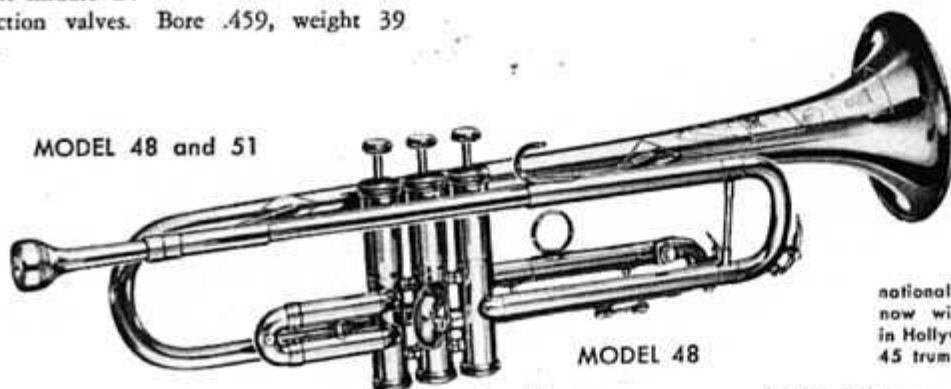

MODEL 48

MODEL 51

Developed by Holton for professionals who demand the ultimate in large bore power, brilliance and response, this trumpet has met with enthusiastic praise wherever it has appeared. With all of its power house capacity, it retains the fine tonal coloring, exceptional flexibility, fine intonation and easy blowing qualities that characterize Holton trumpets. Large bore (.465). B♭ only.

An all purpose trumpet, Model 48 is particularly recommended for those who like plenty of power, unusual freedom of response and a big, yet brilliant, tone. Larger bore mouthpipe and bell give a little more power and a fuller tone than model 45. Yet it has a beautiful and exceptionally easy high register. Top action shrouded spring valves are very light and fast. Bore .459, bell diameter 4 13/16 inches, weight approximately 39 ounces.



JIMMY ZITO
nationally known trumpeter
now with M.G.M. Studios in
Hollywood and his Holton
45 trumpet.



GORDON BRAUND
Canadian Network
Artist



EDWARD SMEALL
Dean of Canada's
trumpet instructors



NELSON WILLIAMS
Free lance artist



Frankie Masters (left) and trumpeters Ray McIntosh, Andy Marchese and Tommy Fitzsimmons, all equipped with Holton model 45 trumpets which were preferred for their tone with just the right amount of "edge".